

**Submittal Data: GAA15AE-D3RNB5B** 15,000 BTU/H PTAC Heat Pump Air Conditioner

Job Name: \_\_\_\_\_ Location: \_\_\_\_\_ Date: \_\_\_\_\_

Purchaser: \_\_\_\_\_ Engineer: \_\_\_\_\_

Submitted to: \_\_\_\_\_ For:  Reference  Approval  Construction

Unit Designation: \_\_\_\_\_ Schedule No.: \_\_\_\_\_

**GENERAL FEATURES:**  
 - Cooling and Heating  
 - 5kW Electric Heat  
 - R-410a Refrigerant  
 - Compact and Quiet Design  
 - Auto Restart Function  
 - LED Display  
 - 3 Speed-Fan



**System Ratings**

<b>Ratings</b>	
Rated Cooling Capacity	14,200 / 14,500 BTU/H
Power Input (Cooling)	1365 / 1390 W
Power Current (Cooling)	6.2 / 6.7 A
EER	10.4
Rated Heating Capacity	13,000 / 13,300 BTU/H
Power Input (Heating)	1225 / 1255 W
Electric Heating Power Input	2820/3450 W
COP	3.1

<b>Compressor</b>	
Type	Rotary
RLA	5.9 A
LRA	28.9 A

<b>Unit Dimensions/Weight</b>	
Dimensions	42 x 16 x 21-1/2-in 1066.8 x 406.4 x 546.1-mm
Net Weight	56 lbs 25.4 kg

<b>Power Supply</b>	
Normal Operational Voltage	208-230 V, 1 Phase, 60 Hz

**Indoor Side Data**

<b>Fan Motor</b>	
Output Power	23 W
RLA	0.20 A
<b>Speed</b>	
Cooling Speed	970/1130 r/min
Heating Speed	970/1130 r/min
<b>Sound Level</b>	
Sound Pressure Level	51 - 54 dB (A)
Sound Power Level	61 - 64 dB (A)

**Outdoor Side Data**

<b>Fan Motor</b>	
Output Power	65 W
RLA	0.52 A
<b>Airflow</b>	
Air Flow Volume	588.5 CFM
<b>Sound Level</b>	
Sound Pressure Level	59/61/63 dB (A)
Sound Power Level	69/71/73 dB (A)
<b>Moisture Protection</b>	
IP24	

<b>Refrigerant Piping Data</b>	
Evaporator Pipe Diameter	8/29-in
Condenser Pipe Diameter	8/29-in

# Outline Dimension Diagram

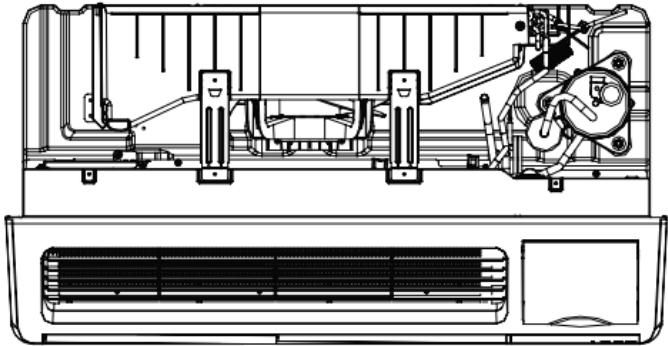
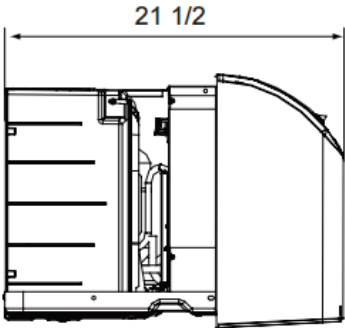
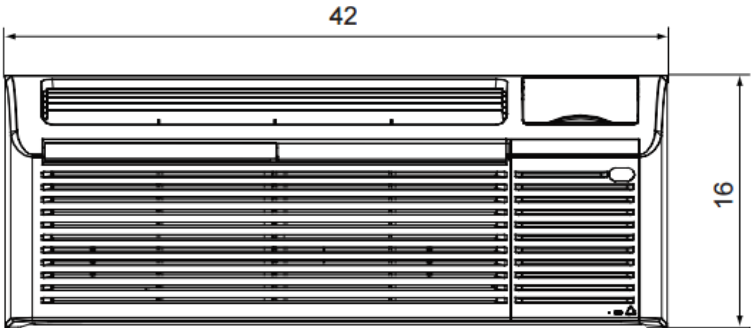

Unit:inch

Weight (net/gross): 56/65 lbs